



ICON
CANAPÉ
design Carlo Colombo
2020

Luxe discret, élégance et confort sont les pierres angulaires de ces assises modulaires. Un projet moderne et linéaire où les détails font la différence: l'étude minutieuse des proportions; le moelleux des dossiers et des accoudoirs au rebondi délibérément accentué; la perfection des surpiquûres visibles réalisées avec un savoir-faire sartorial savant.

Même dans les compositions plus grandes et plus articulées, Icon se distingue par son image de légèreté, grâce à la haute structure du sol et aux détails visibles de la base et des pieds de support en aluminium avec une finition nickel noir brillant ou bruni mat.

Le revêtement peut être en tissu ou en cuir complètement déhoussable; les sièges sont rendus encore plus confortables par une série de coussins en plumes carrées, en deux tailles et avec revêtement déhoussable en tissu ou en cuir avec passepoil.

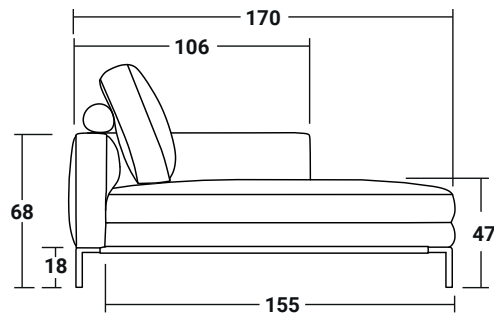
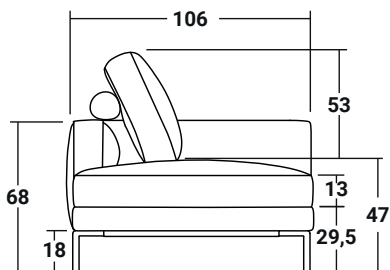
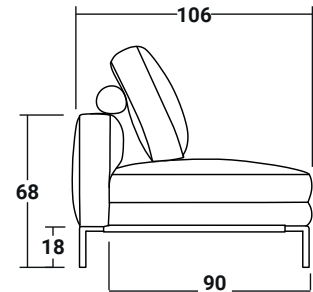
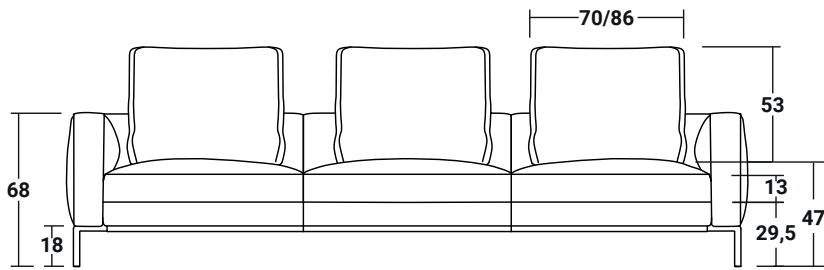
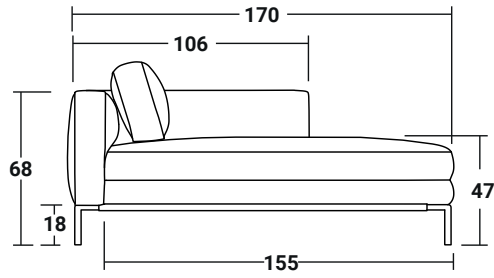
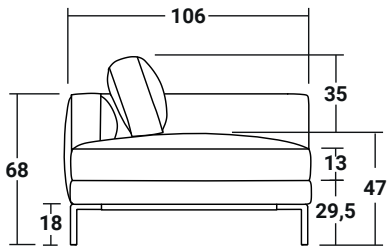
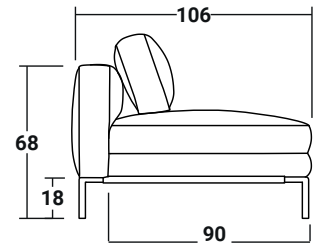
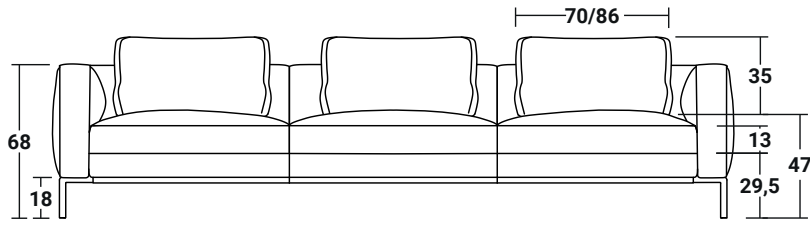

CDII 301

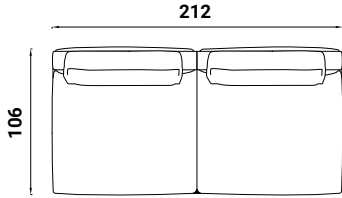

CDII 302

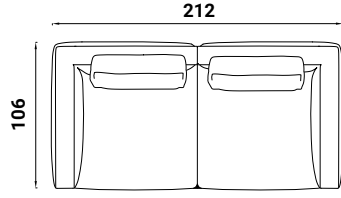

CDII 303

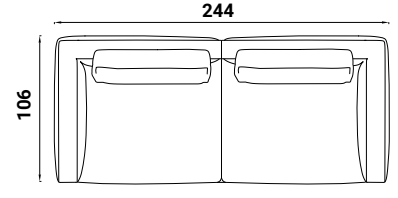

CDII 304

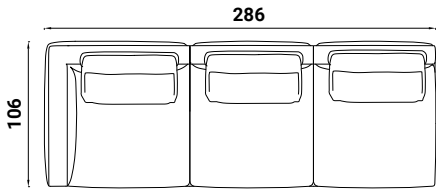

CDII 305

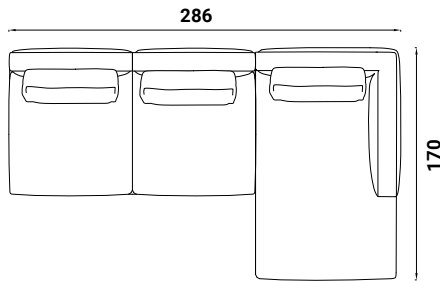

CDII 306

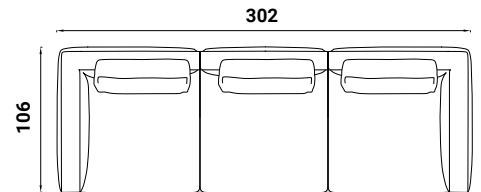

CDII 307

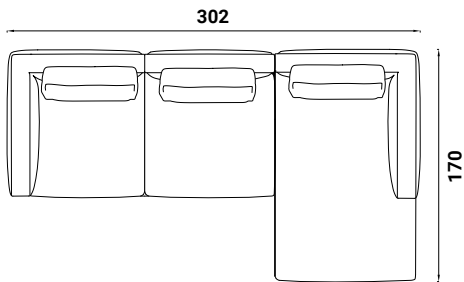

CDII 308

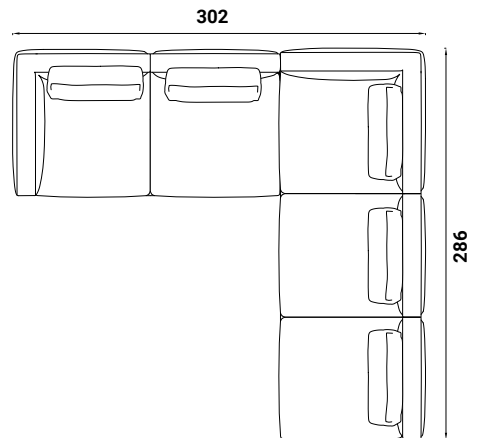

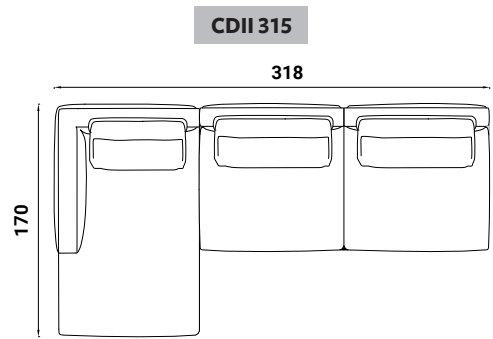
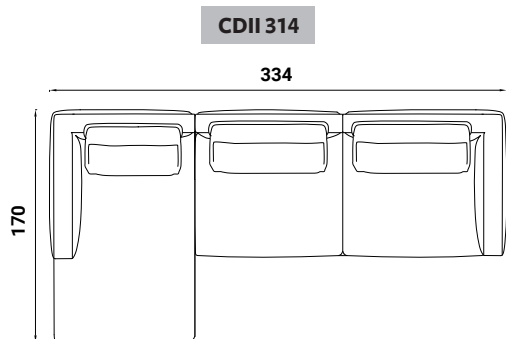
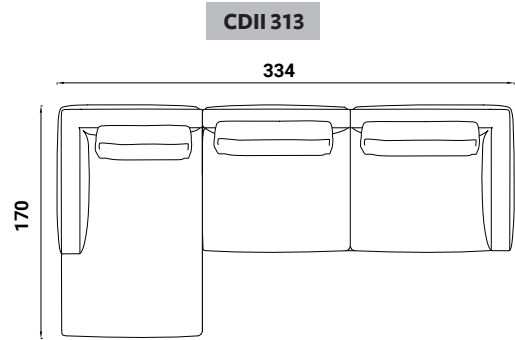
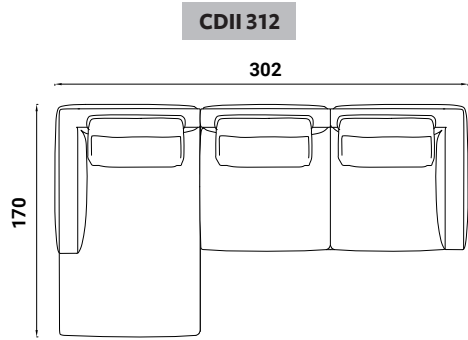
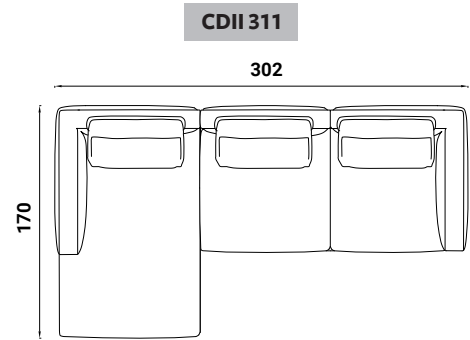
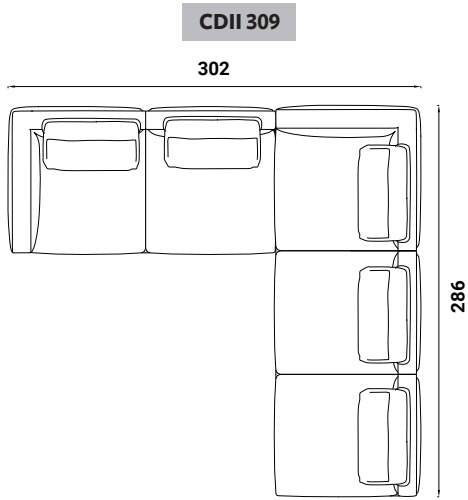

CDII 316

392

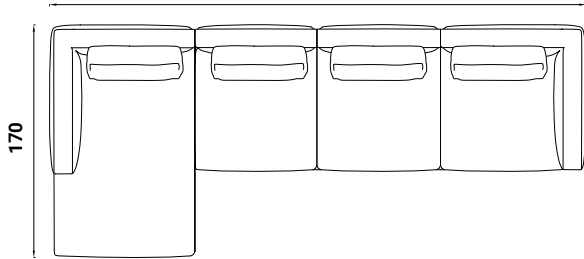

CDII 317

392

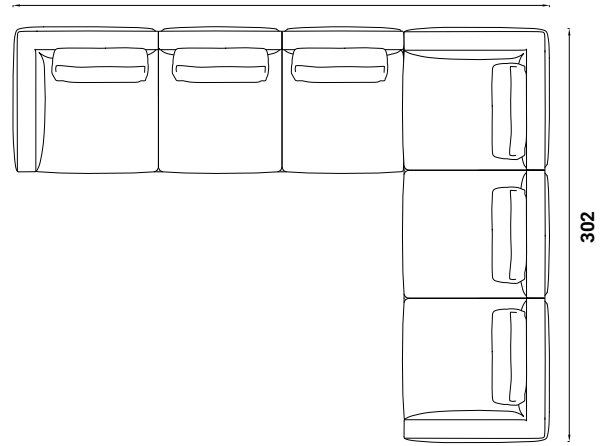

CDII 318

392

